

QS1 Intelligent single loop life safety control panel

Features

- Supports up to 250 Signature Series intelligent devices
- Combines the Signature intelligent releasing module with Signature multisensor detectors for reliable suppression
- Failsafe mode ensures uncompromised reliability
- Class A (Style 7) or Class B (Style 4) wiring options
- Capacity for eight serial annunciators
- Four built-in system relays
- Optional dual line dialer supports Contact ID and 4/2 formats
- Three methods of programming: *QuickStart* "auto-learn," front panel and personal computer (PC)
- Supports optional barcode scanner for direct device data entry
- Optional bank of 30 front panel switches with dual LEDs
- Up to 20 adjustable pre-alarm settings for Signature smoke detectors
- Wallboxes available in red or gray with optional trim ring for semi-flush mounting.
- Large 14-line (224 character) backlit LCD display
- Four password levels, plus priority access keyswitch
- Message routing by event type or by individual message
- Alarm sensitivity by time of day or manual selection
- 1,000 event history buffer, plus alarm history counter
- 6 amp Power Supply, 4.75 amps available for external use
- ULC-S527-99 compliant
- Compare utility identifies system changes and simplifies testing

Description

EST's QS1 life safety control panel brings big-system intelligent control to small applications. Designed for easy setup and simple installation, QuickStart lives up to its name in every respect. QS1's exclusive *QuickStart* auto-learn function, and the option of configuring the panel using convenient front panel programming or from a PC, makes short work of system setup. Devices come on-line in no time as well, thanks to QS1's built-in barcode scanner



port. A simple pass of the optional scanner is all it takes to store device information in the QuickStart database. The scanner can also be used for quick and easy text entry when assembling custom messages.

QS1's setup routine is deceptively simple, considering this system's robust features. Supporting up to 250 intelligent detectors and modules, QS1 takes full advantage of EST's exclusive Signature Series technology, which provides electronic addressing, automatic device mapping, environmental compensation, and true multisensor detection.

QuickStart's innovative design makes it easy to add a dialer or extra auxiliary relays. Quick-Lok option cards snap onto QS1's easily-accessible DIN mounting rails. QS1 also supports as many as eight remote annunciators and up to 30 programmable front panel switches with dual LEDs for system control and display.

QS1 is as simple to operate as it is to set up. Its large 14-line backlit LCD display provides easy-to-understand details concerning up to 1,000 system events, while bright system status LEDs and large, tactile control buttons present the user with a clean, crystal clear interface. Four password levels limit control and information retrieval to authorized personnel. A priority access keyswitch gives Level 2 access without a password to management and emergency personnel.

Application

Thanks to its flexibility and simple setup and operation, QS1 is ideal for new installations in schools, apartment buildings, hospitals, office buildings, and retail facilities.

The benefits brought by QS1 to retrofit applications underscores the true potential of this powerful system. As an intelligent panel, QS1 supports Signature Series devices, which can use existing wiring in most retrofit applications. This makes upgrading from a conventional system to analog control a simple operation with minimal disruption to normal operations at the site.

EST INTERNATIONAL

201 CITY CENTRE DRIVE SUITE 500, MISSISSAUGA, ONTARIO, CANADA L5B 2T4

PHONE: (001)905-270-1711 • FAX: (001)905-270-9553 • WORLD WIDE WEB: WWW.ESTINTERNATIONAL.COM

U.S. SALES: SARASOTA, FL; PHONE 941-739-4200; FAX 941-727-0740 • CANADA SALES: OWEN SOUND, ON; PHONE 519-376-2430; FAX 519-376-7258

Operation

Indicators

1. **Text display and controls:** Displays system messages, status information, and programming menus. Arrow buttons move the display cursor.
2. **Alarm LED:** Indicates a fire or life threatening emergency.
3. **Supervisory LED:** Indicates an off-normal condition with the fire suppression system or related equipment.
4. **Disable/Test LED:** Indicates part of the system is disabled or being tested. Disabled components also signal a system trouble.
5. **Monitor LED:** Indicates the operation of an ancillary system function (door closures, fan pressure switches).
6. **Trouble LED:** Indicates an off-normal condition or wiring fault that compromises the integrity of the system.
7. **Ground Fault LED:** Indicates a ground fault in the system wiring. Ground faults also signal a system trouble.
8. **CPU Fail LED:** Indicates an unexpected reboot or failure with the microprocessor. CPU failures also signal a system trouble.
9. **Power LED:** Indicates the panel has power.
10. **Help button:** Provides additional information about the device selected on the display.
11. **Status button:** Displays the Status Menu from which you can identify active or disabled points in the system.
12. **Panel Silence/Acknowledge button and LED:** Acknowledges all events posted in the display queues and turns off the panel buzzer. The panel silenced LED indicates that off normal events have been acknowledged.

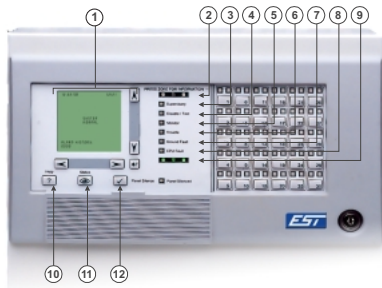

Controls

13. **Reset button:** Allows devices or zones in alarm or trouble to restore to their standby condition. The LED indicates that the panel is resetting.
14. **Alarm Silence button:** Turns active notification appliances off depending on panel programming. Pressing Alarm Silence a second time turns them back on. The LED indicates that the panel is in alarm and operating with notification appliances turned off.
15. **Drill button:** Activates notification appliances depending on panel programming but does not place the panel in alarm. The LED indicates that the panel is in Drill Mode.
16. **Menu button:** Displays the operator menus.
17. **Delete button:** Returns to the previous menu or backspaces the cursor.
18. **Enter button:** Press the Enter button to accept information or continue to the next item.
19. **Numeric keypad:** Numbered buttons for entering values and making menu selections.
20. **Barcode scanner jack:** Input for optional barcode scanner.
21. **Priority Access keyswitch:** Enables control functions reserved for access level 2 and above without requiring a password.

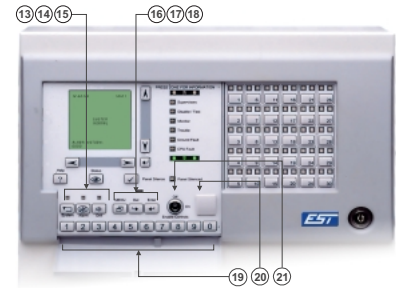

CPU / LCD Display

The QS1 front panel display provides 14 lines by 16 characters of text detailing event, device, diagnostic, and programming information. Its large backlit LCD screen is easy to read and always provides at-a-glance indication of the system's state of operation.

The CPU/Display Unit houses the CPU card and mounting space for one optional LED/Switch card.

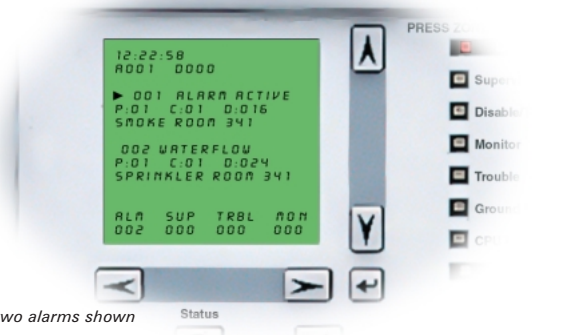

Display with two alarms shown

Specifications

Operating environment	Temperature: 32–120 °F (0–49 °C) Humidity: 93 %RH, non-condensing
Current requirements	Standby: 117 mA when connected to PS6; 105 mA when connected as a remote annunciator Alarm: 135 mA when connected to PS6; 123 mA when connected as a remote annunciator

Failsafe Mode

If the CPU loses communication with other circuit cards, the power supply card continues to monitor the system for any alarm events. If an alarm occurs on any device or circuit during a communications failure, the power supply activates all alarm outputs and instructs the dialer to transmit a default alarm message to the monitoring station.

Typical Wiring

Class A Signature Data Circuit

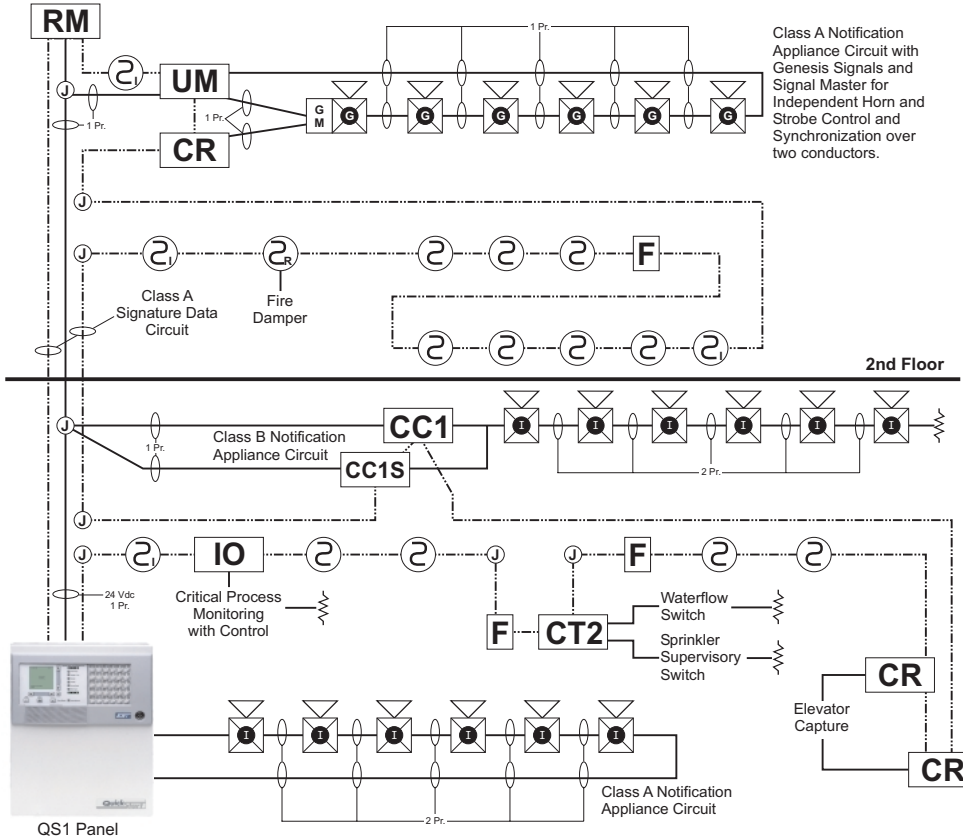

LEGEND

	Enhanced Integrity Horn-Strobe		End-of-Line Resistor
	Genesis Horn-Strobe		Programmable I/O Module
	Genesis Signal Master		Universal I/O Module
	Smoke Detector		Dual Circuit Input Module
	2-Wire Smoke Detector		Control Relay Module
	Smoke Detector with Relay Base		Signal Module
	Smoke Detector with Isolator Base		Signal Module (synchronization)
	Manual Pull Station		Riser Monitor Module
	Junction Box		Monitor Module

More wiring suggestions can be found in the QS1 Fire Alarm Control Panel Installation, Operation, and Maintenance Manual, P/N 3100184.

Dimensions

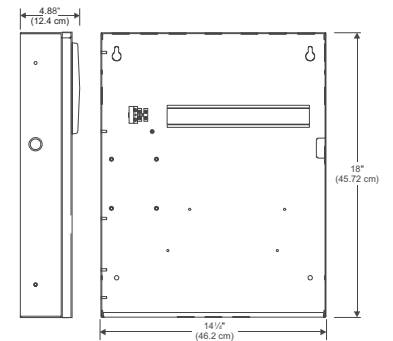

Mounting

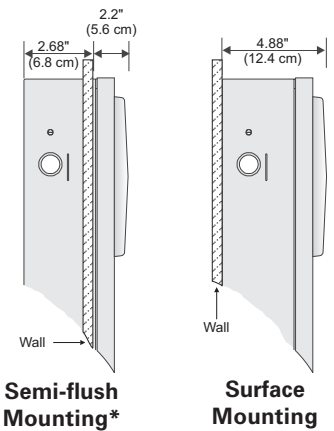

*Semi-flush mounting requires an optional trim ring, which adds 3/4" to all sides of the panel.

Class B Signature Data Circuit

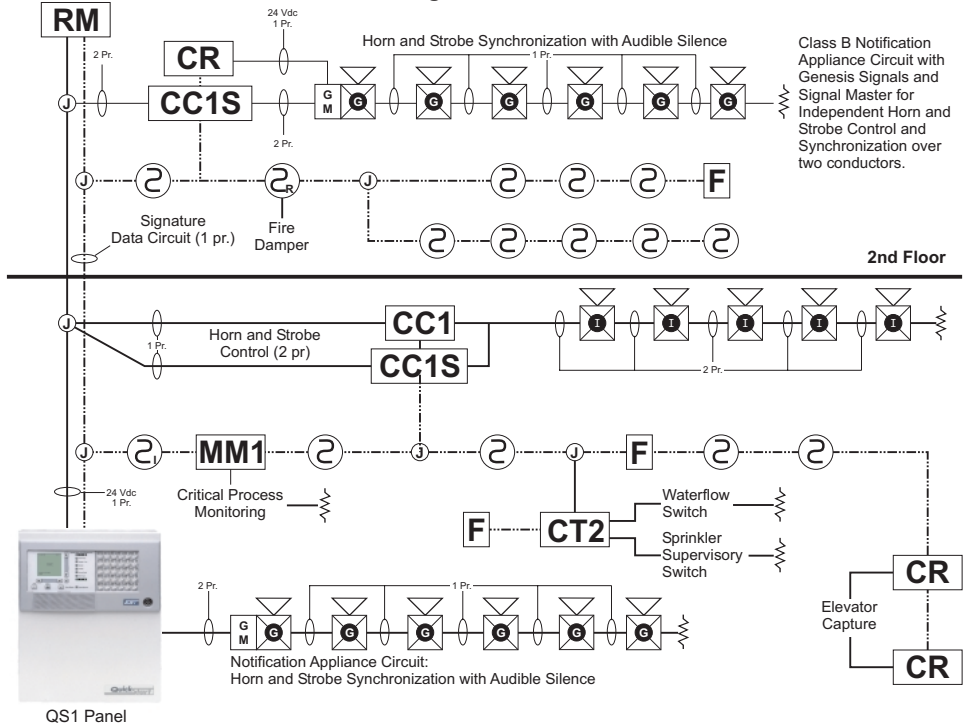

Standard Components and Option Cards

QS1 panels come standard with a CPU/Display Unit, an SLIC Signature Loop Controller, and a PS6 Power Supply (see ordering information for details).

Available QS1 option cards provide dialing capability or extra relays for ancillary control. Quick-Lok option cards snap onto DIN mounting rails for fast, no-fuss installation. One option card space is available.



Cabinet with option card and batteries installed.

STANDARD COMPONENT

Power Supply Card

PS6

The PS6 provides primary dc power to all the circuit cards installed in the cabinet. There are four 24 Vdc power output circuits – three for powering auxiliary applications, and one for powering four-wire smoke detectors – and a charging circuit for standby batteries. The PS6 also provides common alarm, supervisory, and trouble relays, as well as a fourth relay that is user programmable.

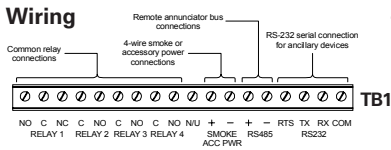
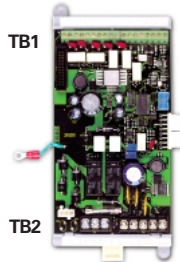

- Relay 1:** Form C. Contacts change position when the control panel processes an alarm signal and remain changed until all active alarm inputs restore and the control panel resets.
- Relay 2:** Form A. Contacts change position when the panel processes a supervisory signal and remains changed until all active supervisory inputs restore.
- Relay 3:** Form A. Contacts change position when the panel loses power or processes a trouble signal and remains changed until power returns or the trouble clears.
- Relay 4:** Form A. Relay closes and opens according to panel programming.
- Smoke/Accessory Power:** Jumper setting determines if the 24 Vdc is constant or resettable.

Specifications

Main supply circuit	AC input: 115 or 230 Vac, 50/60 Hertz DC input: 24 Vdc batteries
Battery charging circuit	Charge current: 2 amps Charge capacity: 40 amp hours (UL) 30 amp hours (ULC)
Smoke/Accessory power output circuit	Voltage: 24 Vdc, regulated Current: 250 mA Wire size: 12 to 18 (0.75 to 2.5 mm ²)
Auxiliary power output circuits	Quantity: 3 Voltage: 24 vdc full wave rectified Current: 1.5 amps each
Common alarm relay	Style: Form C Contact rating: 1 amp Wire size: 18 to 12 AWG (0.75 to 2.5 mm ²)
Trouble, Supervisory and programmable relays	Style: Form A (N/O) Contact rating: 1 amp Wire size: 18 to 12 AWG (0.75 to 2.5 mm ²)
Operating environment	Temperature: 32 - 120° F (0 - 49° C) Humidity: 93 %RH, non-condensing
Current requirements	Standby current: 72 mA Alarm current: 96 mA

STANDARD COMPONENT

Signature Loop Intelligent Controller

SLIC

The SLIC provides one Class A or Class B data circuit (loop) for connecting Signature Series detectors and modules. The SLIC also provides two programmable Class A or Class B notification appliance circuits (NACs) for connecting polarized 24 Vdc notification appliances such as horns and strobes. QS1 supports one SLIC.

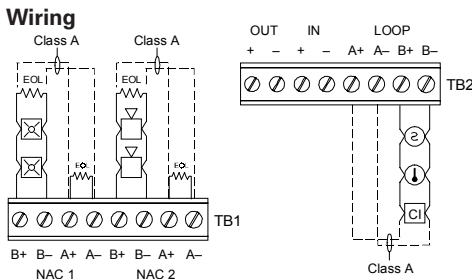

Signaling Line Circuit and NACs are supervised and power-limited.

Specifications

Signaling line circuit	Configuration: Class B (Style 4) or Class A (Style 7) Capacity: 125 Signature detectors 125 Signature modules Wire size: 18 to 12 AWG (0.75 to 2.5 mm ²) Circuit resistance: 65 ohms Circuit capacitance: 0.3 μf
Notification appliance circuits #1 and #2	Configuration: Class B or Class A Output voltage: 24 Vdc, nominal Output current: 2.0 A at 24 Vdc for #1 and 1.0 A at 24 Vdc for #2 Wire size: 18 to 12 AWG (0.75 to 2.5 mm ²) End of line resistor: 10k ohms, ½ W
NAC power input circuit	Voltage: 24•Vdc, nominal Wire size: 18 to 12 AWG (0.75 to 2.5 mm ²)
Operating environment	Temperature: 32 - 120° F (0 - 49° C) Humidity: 93 %RH, non-condensing
Current requirements	Standby current: 33 mA Alarm current: 57 mA (Both NACs on)
Card spaces	Requires one card space.

Dialer

The DLD is a ULI/ULC listed dual line Digital Alarm Communicating Transmitter (DACT). It provides two phone line connections for sending system messages to a compatible Digital Alarm Communicator Receiver. The DLD supports 4/2 and Contact ID formats. It occupies one card space on the chassis rail.

Wiring

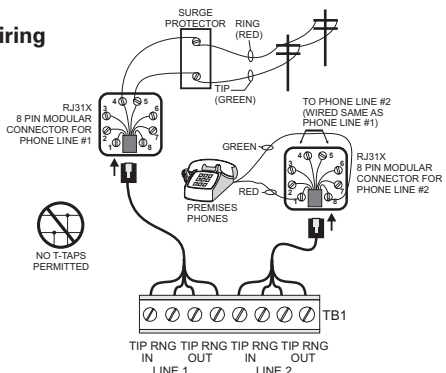

Specifications

Operating environment	Temperature: 32 - 120 ° F (0 - 49 ° C) Humidity: 93% RH, non-condensing
Current requirements	Standby: 13 mA Dialing: 26 mA
Phone Lines	Two loop start lines on switched telephone network. Pulse or DTMF dialing.
Wall Connector	RJ31X/CA31A equiv. or RJ38X/CA38A equiv.
Communications Protocol	Contact ID (SIA DC-05), 4/2 (SIA DC-02 P3).
Programming	Via QuickStart, Front Panel or PC.
Communications Compliance	Communications Canada CS-03FCC/CFR 47 Parts 15 and 68, NFPA 72, ULI 864, ULC S527-M87
Receivers	Signals can be transmitted to either or both of two receivers.
Telephone #s	Two 24-digit numbers per receiver.
Card spaces	Requires one card space.

Relay Card

The ZR8 provides eight dry-contact relays that can be independently configured as Form A or Form B relays. It occupies one card space on the chassis rail.

Wiring

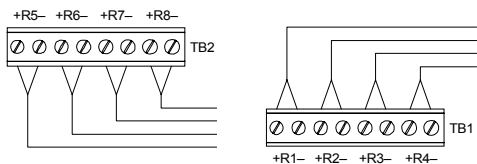

Specifications

Output relays	Style: Form A or Form B (jumper configurable) Contact rating: 1 amp @ 30 Vdc resistive. Wire size: 18 to 12 AWG (0.75 to 2.5 mm ²)
Operating environment	Temperature: 32 - 120° F (0 - 49° C) Humidity: 93 %RH, non-condensing
Current requirements	Standby current: 7 mA Alarm current: 18 ma per active relay
Card spaces	Requires one card space.

Class A RS-485 Card and QS-232 Port

The NT-A, which includes the X485/RS-485 card and QS-232/UART port, provides one Class A serial remote annunciator bus for connecting remote annunciator panels. Control panels require the X485 card and QS-232 port, which also serves as a laptop or printer port. The X485 occupies one card space on the chassis rail. The QS-232 port plugs into the panel CPU.

Wiring

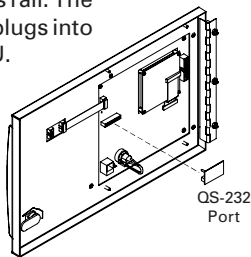
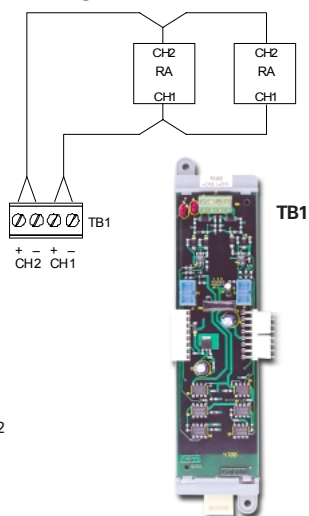

Specifications

Wire size	12 to 18 AWG (0.75 to 2.5 mm ²) twisted pair (6 twists per foot minimum)
Circuit resistance	100 Ohms
Circuit capacitance	0.4 μF
Operating environment	Temperature: 32 - 120° F (0 - 49° C) Humidity: 93 %RH, noncondensing
Current requirements	Standby: 75 mA Alarm: 75 mA
Card Spaces	Requires one space for the NT-A

The SL30 provides thirty switches with two associated LEDs per switch. These switches and associated LEDs can be used for point or zone annunciation of alarm, supervisory, monitor, and trouble signals. Buttons on the SL30 are numbered 1 through 30.



Specifications

Operating environment	Temperature: 32 - 120 ° F (0 - 49 ° C) Humidity: 93% RH, non-condensing
Current requirements	Standby: 1mA Alarm: 0.75 mA per active LED

Remote Annunciators

QS1 supports up to eight remote annunciators, which provide mirrored or customized annunciation of front panel messages and status indicators. Remote annunciators connect directly to the PS6 Power Supply Card or an external 24 Vdc filtered supply. They are available with wallboxes for flush or surface mounting.

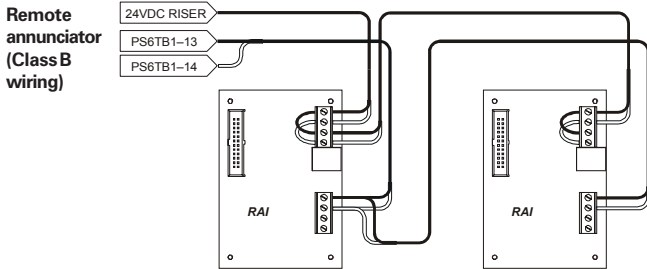

Remote Annunciator Dimensions	Model	Height	Width	Depth
	QSA-1-S	7.6" (11.68 cm)	14.25" (36.20 cm)	2.9" (7.3 cm)
	QSA-1-F (rough in)	6.56" (16.66 cm)	13.25" (33.66 cm)	2.1" (5.33 cm)
	QSA-1-F (finished)	7.8" (19.81 cm)	14.42" (36.63 cm)	1.38" (3.49 cm)

*Rough-in dimensions reflect the size of the cabinet where it enters the wall.
Finished dimensions reflect the size of the cabinet that protrudes from the wall.*

Ordering options

(Apply to basic packages and CPU/displays only)

Languages

- No suffix = American English
- BR = British English (230v only)
- SP = Spanish (230v or 115v)
- PG = Portuguese (230v only)
- FR = French Canadian (120v only)

Power Supplies

- 1 = 115v transformer
- 2 = 230v transformer

Colors

- G = Grey enclosure (230v or 115v)
- R = Red enclosure (115v only)

Examples

QS1-1-G-2-SP = QS1 basic package with one option card space, grey enclosure, 230v transformer, Spanish language.

QS1-CPU-FR = QS1 CPU/display, French Canadian.

Which Quickstart Panel is right for you?	QSC	QS1	QS4
Signature Series devices supported	0	1 x 250	4 x 250
Conventional Class B circuits supported	3 x 16	0	3 x 16
Conventional Class A circuits supported	5 x 8	0	5 x 8
LCD display (lines x characters)	4 x 20	14 x 16	14 x 16
Optional Zone Switch/LEDs on front panel	2 x 30	1 x 30	2 x 30
Option card spaces	5 or 12	1	5 or 12
For more information, see catalog sheet number ...	85005 -0112	This Sheet	85005 -0114

Ordering Information

Part Number	Description	Ship Wt. lb. (kg.)
Basic Package - Enclosure, SLIC, Power Supply, CPU and Display		
QS1-1-G-1	Single Loop System. One option card space. Grey enclosure with 115v transformer.	17.0 (7.71)
QS1-1-R-1	Single Loop System. One option card space. Red enclosure with 115v transformer.	17.0 (7.71)

Note: SLIC Card includes One Signature Loop Intelligent Controller for up to 250 devices and one Class A or two Class B NACs.

Enclosure Accessories

TRIM-1	Trim Kit - gray	5.0 (2.27)
TRIM-1R	Trim Kit - red	5.0 (2.27)

Option Cards

DLD	Dual Line Dialer. Supports 4/2 and Contact ID formats.	1.0 (0.45)
ZR8	Relay Card. 8 programmable Form A contacts.	1.0 (0.45)

Display Options

SL30	Annunciator module. Numbered 1 to 30. Two LEDs and one switch per zone.	1.0 (0.45)
QS1-CPU-1	Single Loop CPU/Display, one annunciator option space	4.0 (1.81)
NT-A	RS-485 option card. Required for Class A remote annunciation. Includes UART card.	1.0 (0.45)
QS-232	UART option card. Plugs into CPU. Required for PC Programming / printer port. Included in NT-A package	1.0 (0.45)

Remote Annunciator Cabinets

(c/w Interface Assembly; Require CPU/Display)

QSA-1-S	Surface Remote Annunciator Cabinet. Space for one SL30 display card.	4.0 (1.81)
QSA-1-F	Flush Remote Annunciator Cabinet. Space for one SL30 display card.	4.0 (1.81)

Programming Tools

QS-CU	QuickStart Panel Configuration Utility.	1.0 (0.45)
QS-Scan	QuickStart scanner and programming guide.	2.0 (0.91)
260097	Programming cable (PC to QSC, QS1, QS4)	1.0 (0.45)
360136	Programming cable (PC to Annunciators)	1.0 (0.45)
240507	DB9 to RJ-11 (required with 360136)	1.0 (0.45)

Accessories

PT-1S	SystemPrinter - Desk top Style	14.0 (6.35)
BC-1(R)	Battery Cabinet. Room for one 40 Ah or two 24 Ah batteries.	22.0 (9.98)
MFC-A	MultiFunction Cabinet.	7.0 (3.1)
IOP3A	RS-232 Isolator Module.	3.0 (1.36)
RPM	Reverse Polarity Module.	3.0 (1.36)
2-CTM	City Tie Module.	1.0 (0.45)
API-8/232ME	Alphanumeric Pager Interface.	11.0 (5.0)
BPS6	6.5 Amp Booster Power Supply, 110 V	13.0 (5.9)
BPS10	10 Amp Booster Power Supply, 110 V	13.0 (5.9)
CDR3	PSNI Coder Module	1.0 (0.45)

EST INTERNATIONAL

It is our intention to keep the product information current and accurate. We can not cover specific applications or anticipate all requirements. All specifications are subject to change without notice. For more information or questions relative to this Specification Sheet, contact EST International.